

1000 BASE -T MAGNETICS MODULES

P/N: GST5009M LF DATA SHEET

Feature

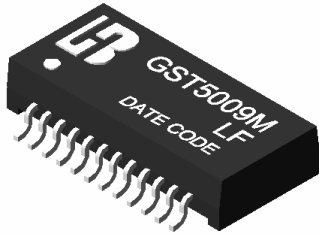

- Designed for long haul gigabit Ethernet 1000 BASE-T, full duplex applications.
- Supports 4 pairs of category 5 UTP cable.
- Cable interface for isolation and low common mode emissions.
- Compliant with IEEE 802.3ab standard for 1000 BASE-T.
- Comply with RoHS requirements-whole part No Cd, No Hg, No Cr6+, No PBB and PBDE and No Pb on external pins.
- Operating temperature range: -40 to +85 .
- Storage temperature range: -40 to +125 .

Electrical Specifications @ 25°C

| Part Number | Turns Ratio (±5%) | | OCL (uH Min) @100KHz/0.1V with 8mA DC Bias | Cross talk Attenuation (dB Min) | | | HI-POT (Vrms) |
|-------------|----------------------|---------|--|------------------------------------|-------|--------|------------------|
| | TX | RX | | 30MHz | 60MHz | 100MHz | |
| GST5009MLF | 1CT:1CT | 1CT:1CT | 350 | -45 | -40 | -35 | 1500 |

Continue

| Part Number | Insertion Loss (dB Max) | Return Loss (dB Min)@ Load 100 | | | | | DCMR (dB Min) | | |
|-------------|----------------------------|-----------------------------------|---------|-------|-------|----------|------------------|-------|-------|
| | | 1-100MHz | 1-30MHz | 40MHz | 50MHz | 60-80MHz | 100MHz | 30MHz | 60MHz |
| GST5009MLF | -1.0 | -18 | -14.4 | -13.1 | -12 | -10 | -40 | -35 | -30 |

Schematic

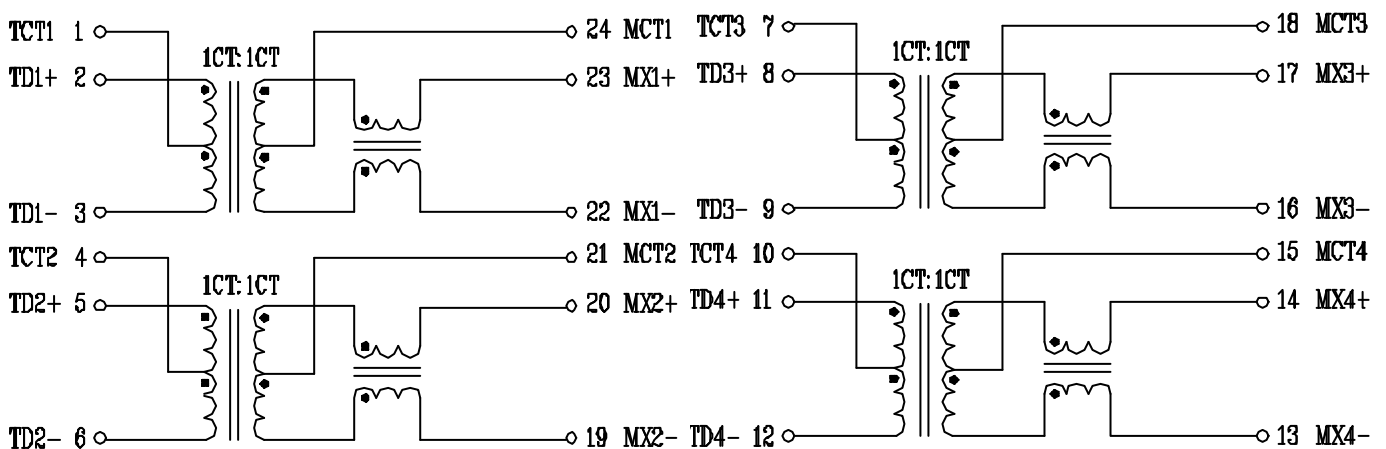

1000 BASE -T MAGNETICS MODULES

P/N: GST5009M LF DATA SHEET

Mechanical

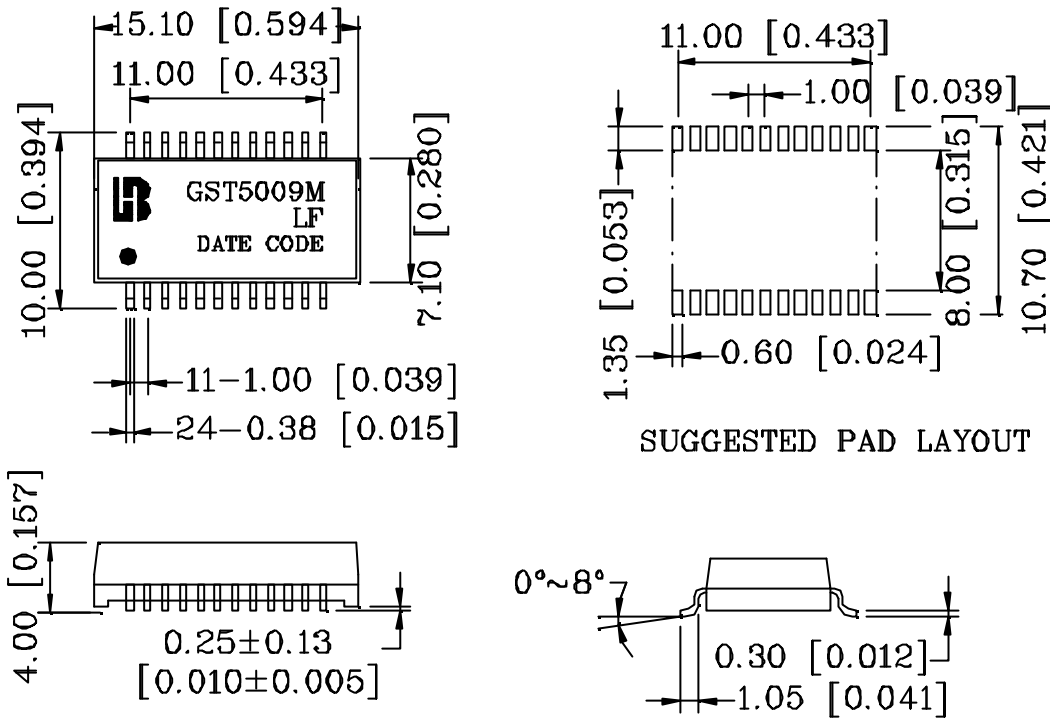

Units: mm[Inches] Tolerances: xx.x0±0.25[0.010]
 0.xx±0.05[0.002]