

1000 BASE -T MAGNETICS MODULES

P/N: GST5009-A LF DATA SHEET

Feature

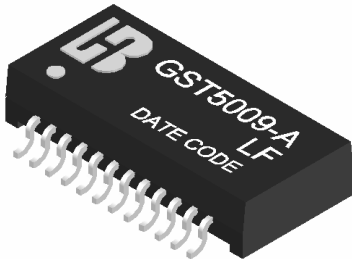

- Designed for long haul gigabit Ethernet 1000 BASE-T, full duplex applications.
- Supports 4 pairs of category 5 UTP cable.
- Cable interface for isolation and low common mode emissions.
- Compliant with IEEE 802.3ab standard for 1000 BASE-T.
- Comply with RoHS requirements-whole part No Cd, No Hg, No Cr6+, No PBB and PBDE and No Pb on external pins.
- Operating temperature range: 0 to +70 .
- Storage temperature range: -25 to +125 .

Electrical Specifications @ 25°C							
Part Number	Turns Ratio (±5%)		OCL (uH Min) @100KHz/0.1V with 8mA DC Bias	Cross talk Attenuation (dB Min)			HI-POT (Vrms)
	TX	RX		30MHz	60MHz	100MHz	
GST5009-ALF	1CT:1CT	1CT:1CT	350	-45	-40	-35	1500

Continue									
Part Number	Insertion Loss (dB Max)	Return Loss (dB Min)@ Load 100					DCMR (dB Min)		
		1-100MHz	1-30MHz	40MHz	50MHz	60-80MHz	100MHz	30MHz	60MHz
GST5009-ALF	-1.0	-18	-14.4	-13.1	-12	-10	-40	-35	-30

Schematic

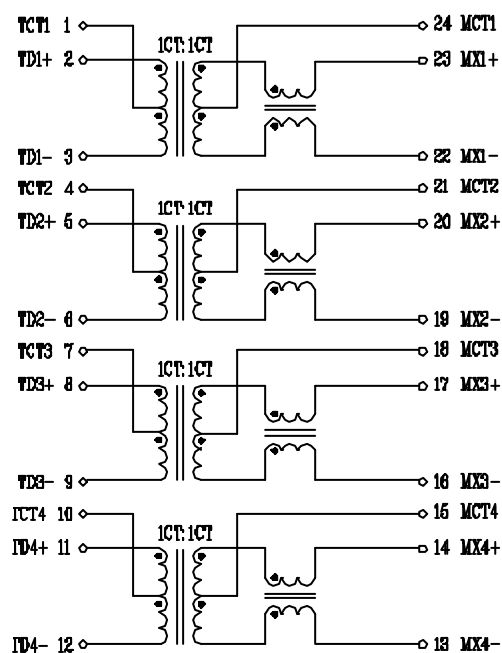

Mechanical

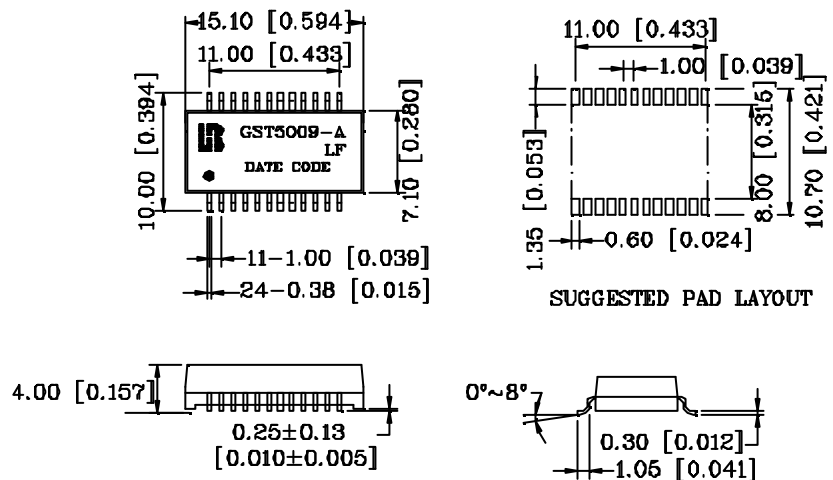

Units: mm[Inches] Tolerances: xx.x0±0.25[0.010]
0.xx±0.05[0.002]