

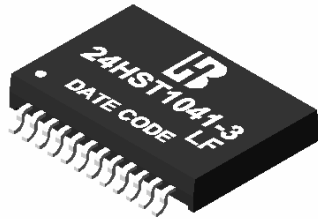

1000 BASE –T MAGNETICS MODULES

P/N: 24HST1041-3 LF DATA SHEET

Feature



- Designed for long haul gigabit Ethernet 1000 BASE-T, full duplex applications.
- Supports 4 pairs of category 5 UTP cable.
- Cable interface for isolation and low common mode emissions.
- Compliant with IEEE 802.3ab standard for 1000 BASE-T.
- Comply with RoHS requirements-whole part No Cd, No Hg, No Cr6+, No PBB and PBDE and No Pb on external pins.
- Comply with Air reflow profile of JEDEC 020C.
- Insulation Resistance: 10,000 M .
- Operating temperature range: 0 to +70 .
- Storage temperature range: -25 to +125 .

Electrical Specifications @ 25°C

Part Number	Turns Ratio (±5%)		OCL (uH Min) @ 100KHz/0.1V with 8mA DC Bias	C _{www} (pF Max)	L.L (uH Max)	Insertion Loss (dB Max) 1-100MHz	HI-POT (Vrms)
	TX	RX					
24HST1041-3 LF	1CT:1CT	1CT:1CT	350	28	0.5	-1.0	1500

Continue

Part Number	Return Loss (dB Min) @ 100					Cross talk Attenuation (dB Min)		DCMR (dB Min)		
	1-30MHz	40MHz	50MHz	60-80MHz	100MHz	0.3-60MHz	60-100MHz	60MHz	100MHz	200MHz
24HST1041-3 LF	-18	-14.4	-13.1	-12	-10	-40	-35	-37	-28	-25

Schematic

Mechanical

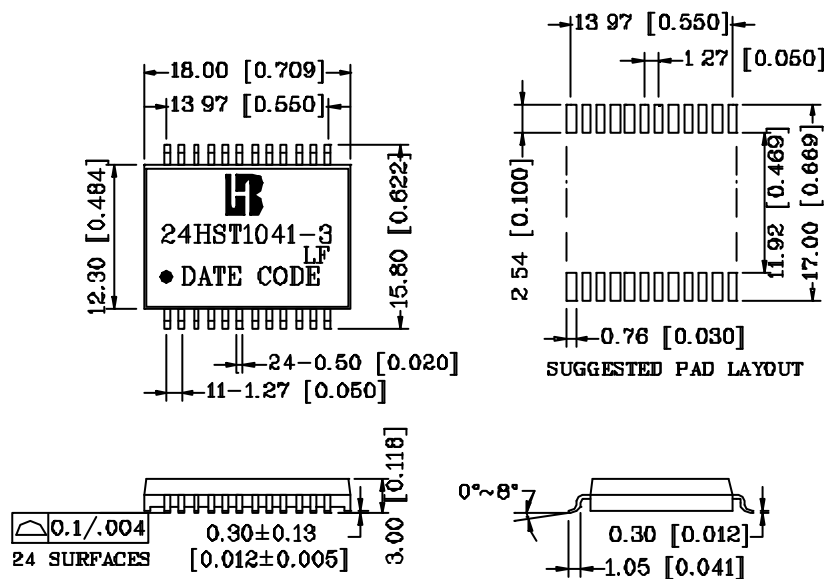
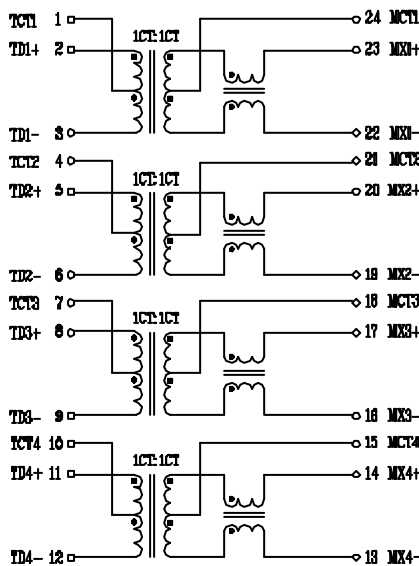

Units: mm [Inches] Tolerances: xx.x0±0.25 [0.010]
0.xx±0.05 [0.002]