

10/100 BASE-T TRANSFORMER

P/N:16PT8515-2 DATA SHEET

Feature

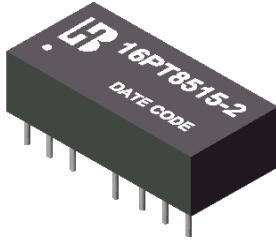

- Designed for 10/100 MB/s transmission over UTP-5 cable.
- Cable interface for isolation and low common mode Emissions.
- Tested & qualified for use with national semiconductor's DP83840 Ethernet 10/100 PHY chip.
- 16-PIN DIP package for economic cost.
- Operating Temperature range: 0°C to +70°C.
- Storage temperature range: -25°C to +125°C.

Electrical Specifications @ 25°C										
Part Number	Turns Ratio (±5%)		OCL (uH Min) @ 100KHz/0.1Vrms with 8mA/DC Bias				CW/W (pF Max)	L.L (uH Max)	Rise Time (10-90%) nS TYP	Voltage Isolation (Vrms)
	TX	RX								
16PT8515-2	1CT:1CT	1CT:1CT	350				28	0.6	2.5	1500
Continue										
Part Number	Insertion Loss (dB Max)		Return Loss (dB Min)				Cross talk (dB Min)		DCMR TX/RX(dB Min)	
	0.3-100 MHz	30MHz	40MHz	50MHz	60MHz	80MHz	0.3-60MHz	60-100MHz	0.3-60MHz	60-100MHz
16PT8515-2	-1.15	-16	-14	-13.5	-13	-12	-35	-30	-30	-25

Schematic

Mechanical

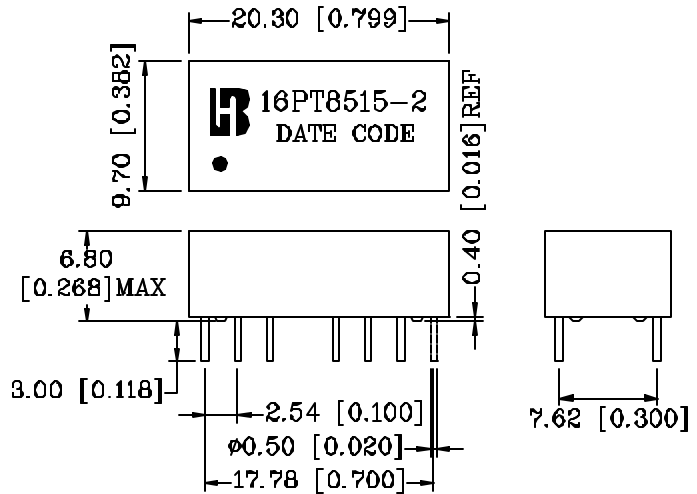
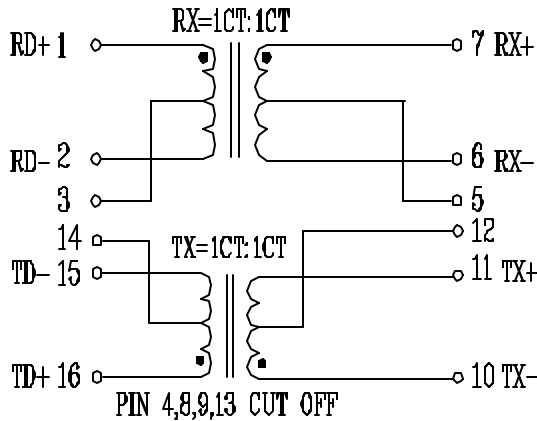

Units: mm[Inches] Tolerances: xx.x0±0.25[0.010]  
0.xx±0.05[0.002]