

P/N: 16ST8517-1 DATA SHEET

Feature

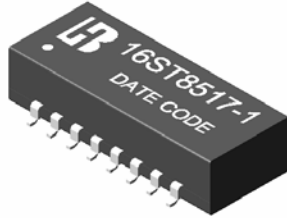

- Designed for 100MB/s and 155MB/s transmission over UTP-5 and STP cable.
- Cable interface for isolation and low common mode emissions.
- Fully integrated modules for multi-port concentrators and Adapter card applications.
- 16-PIN SMD Package □pick and place compatible.
- Operating temperature range: 0°C to +70°C.
- Storage temperature range: -25°C to +125°C.

Electrical Specifications @ 25°C

Part Number	Turns Ratio (±5%)		OCL(μH Min) @100KHz/0.1Vrms with 8mA/DC Bias	C _{www} (pF Max)	L.L. (μH Max)	DCR (Ω Max)	HI-POT (Vrms)	
	RX	TX						
16ST8517-1	1CT:1CT	1CT:1	350	28	0.6	0.9	1500	
Continue								
Part Number	Insertion Loss (dB Max)	Return Loss (dB Min)					Cross talk (dB Min)	
		0.3-100 MHz	0.3-30MHz	40MHz	50MHz	60MHz	60-80MHz	0.3-60MHz
16ST8517-1	-1.15	-16	-14	-13.5	-13	-12	-45	-35

Schematic

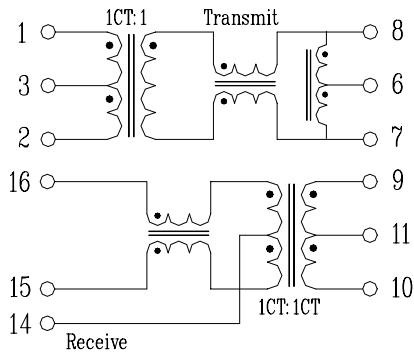

Mechanical

