



10 BASE-T LOW PASS FILTER TRANSMITTER & RECEIVER WITH COMMON CHOKES

APPLY TO GENERIC IC

P/N:FB2028A DATA SHEET

Feature



- Operating temperature range: 0°C to +70°C.
- Storage temperature range: -25°C to +125°C.

Electrical Specifications @ 25°C				
Part Number	Turns Ratio (±5%)		CUT-OFF Frequency	HI-POT (Vrms)
	TX	RX		
FB2028A	1CT:1.41CT	1CT:1CT	17MHz±1.5MHz	1500

Continue										
Part Number	Insertion Loss (dB Max)		Attenuation (dB Min)TX/RX				Return Loss (dB Min)	Cross talk (dB Min)	CMR (dB Min)	
	1-10MHz	5-10MHz	20MHz	25MHz	30MHz	40MHz	5-10MHz	1-10MHz	30-100MHz	
FB2028A	-1.0/RX	-1.5/TX	-7/-6	-19/-14	-30/-20	-32/-31	-17	-30	-30/TX	-24/RX

Schematic

Mechanical

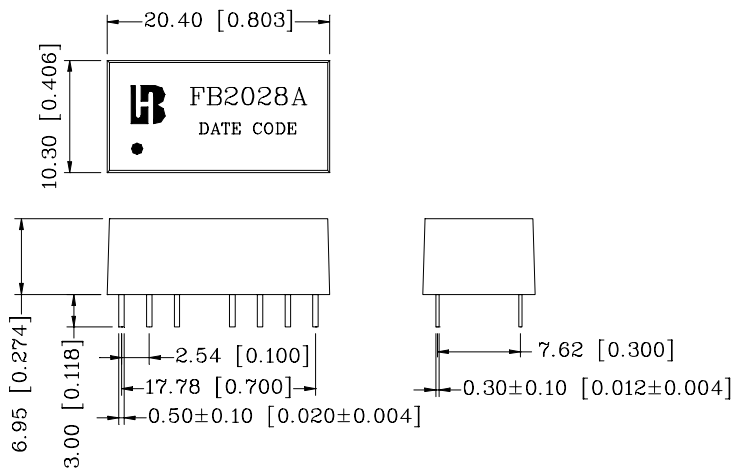
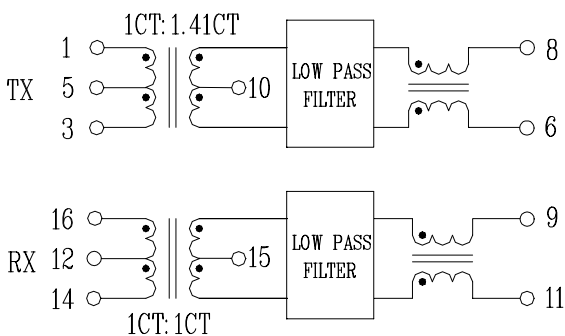

Units: mm[Inches] Tolerances: xx.x0±0.25[0.010] 0.xx±0.05[0.002]