

1. Features :

<ul style="list-style-type: none"> ■ 7 Pin SIL Package 	
<ul style="list-style-type: none"> ■ Low Ripple and Noise 	
<ul style="list-style-type: none"> ■ Input / Output Isolation 500 Vdc 	
<ul style="list-style-type: none"> ■ 100 % Burn-In 	
<ul style="list-style-type: none"> ■ Input Filter with Internal Capacitor 	
<ul style="list-style-type: none"> ■ Custom Design Available 	

2. Absolute maximum ratings :

(Exceeding these values may damage the module. These are not continuous operating ratings)

Parameter	Condition	Min.	Typ.	Max.	Unit
Input Absolute Voltage Range	5V Input Model	-0.7	5	7.5	Vdc
	12V Input Model	-0.7	12	15	
	24V Input Model	-0.7	24	30	
Max. Output power		---	---	1	W
Output Short circuit duration		---	---	1.0	Second
Operating temperature		-40	---	+85	°C
Storage temperature		-55	---	+105	

3. Nominal Input / Output Electrical Specifications :

(Specifications typical at Ta = +25°C , nominal input voltage, rated output current unless otherwise noted)

Parameter	Condition	Min.	Typ.	Max.	Unit
Input Voltage Range	5V Input Model	4.5	5	5.5	Vdc
	12V Input Model	10.8	12	13.2	
	24V Input Model	21.6	24	26.4	
Output Voltage Accuracy	Nominal Input	---	---	± 5.0	%
Voltage Balance (Dual Outputs)		---	---	± 1.0	%
Switching Frequency		---	90	---	KHz
Temperature Coefficient		---	± 0.01	± 0.02	% / °C
Isolation Voltage	60 Seconds / 0.5mA	500	---	---	Vdc
Isolation Resistance	500 Vdc	1000	---	---	MΩ
Isolation Capacitance	1 KHz / 250 V rms	---	50	---	pF
Max. Line Regulation (Per 1.0 % change in input change)		---	---	1.3	%

4. Model Selection Guide :

4.1. 500 Vdc Isolation – Single Output

(Specifications typical at Ta = +25 °C, Nominal input voltage, Rated output current unless otherwise noted)

Bothhand Model No.	Input Voltage (Vdc)	Output Voltage (Vdc)	Output Current (mA) Max.	Input Current @ No Load (mA) Typ.	Input Current @ Max. Load (mA) Typ.	Output Ripple (mV) Max.	Load Regulation (%) Max.	Efficiency (%) Typ.
CAS0505	5	5.0	200	30	253	60	± 9	79
CAS0509		9.0	111	30	253	90	± 8	79
CAS0512		12.0	84	28	254	100	± 8	79
CAS0515		15.0	67	28	251	120	± 8	80
CAS1205	12	5.0	200	18	105	60	± 8	79
CAS1212		12.0	84	18	104	100	± 8	80
CASxxxx								

Notes :

- CASxxxx is for Customer Design.
- Load regulation is for output current change from 20 % to 100 % Max. Load.

Mechanical Dimension :

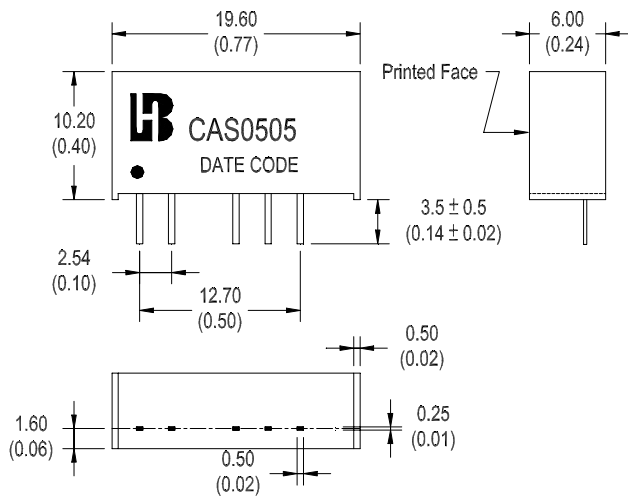

Pin	500Vdc - Single
1	+Vin
2	-Vin
3	---
4	NC
5	Vo (-)
6	Vo (+)
7	---

Note : " --- " means Omitted

Units : mm (inch)

Tolerance : .xx ± 0.25

(± 0.01)

4.2. 500 Vdc Isolation – Dual Output

(Specifications typical at Ta = +25 °C, Nominal input voltage, Rated output current unless otherwise noted)

Bothhand Model No.	Input Voltage (Vdc)	Output Voltage (Vdc)	Output Current (mA) Max.	Input Current @ No Load (mA) Typ.	Input Current @ Max. Load (mA) Typ.	Output Ripple (mV) Max.	Load Regulation (%) Max.	Efficiency (%) Typ.
CAD0505	5	± 5.0	± 100	30	263	70	± 8	76
CAD0512		± 12.0	± 42	28	255	100	± 8	79
CAD0515		± 15.0	± 34	28	255	120	± 8	80
CAD1212	12	± 12.0	± 42	22	104	100	± 8	80
CAD1215		± 15.0	± 34	22	104	120	± 8	80
CAD2415	24	± 15.0	± 34	8	55	120	± 8	76
CADxxxx								

Notes :

- CADxxxx is for Customer Design.
- Load regulation is for output current change from 20 % to 100 % Max. Load.

Mechanical Dimension :

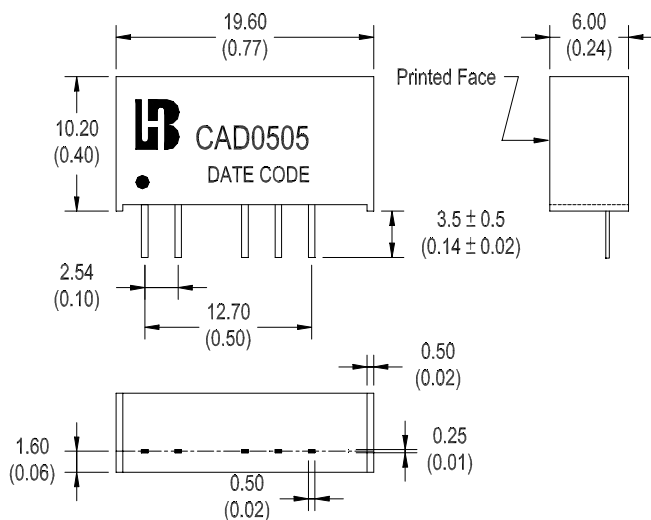

Pin	500Vdc - Dual
1	+Vin
2	-Vin
3	---
4	Vo (-)
5	Common
6	Vo (+)
7	---

Note : " --- " means Omitted

Units : mm (inch)

Tolerance : .xx ± 0.25

(± 0.01)