

INTEGRATED CO SIDE HYBRID FILTER
P/N: VD-7018K DATA SHEET



Bothhand USA. e-mail: sales@bothhandusa.com http://www.bothhand.com

Feature



- Operating Temperature: -10°C to +60°C.
- Storage Temperature: -25°C to +75°C.

Electrical Specifications @ 25°C

Part Number	Description	Pass band Insertion loss (dB Max)	Stop band Insertion loss (dB Min)		Impedance (Ω)
		4.2M ~ 7.8 MHz	900K ~ 3 MHz	3M-3.3MHz	
VD-7018K	Transmit HPF TO LINE	-5.5	-40	-30	270

Additional Specifications

Part Number	Description	Pass band Insertion loss (dB Max)	Stop band Insertion loss (dB Min)			Impedance (Ω)
		900K ~ 3.3 MHz	4.2K ~ 7.8MHz	20K ~ 600KHz	600K~700KHz	
VD-7018K	Receive LPF TO LINE	-7	-15	-45	-30	40

Schematic

Mechanical

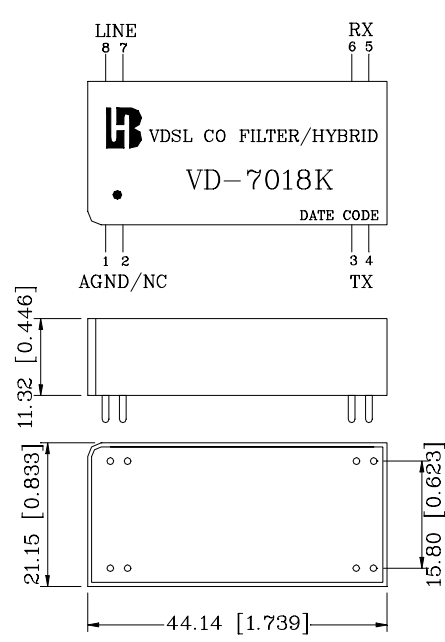
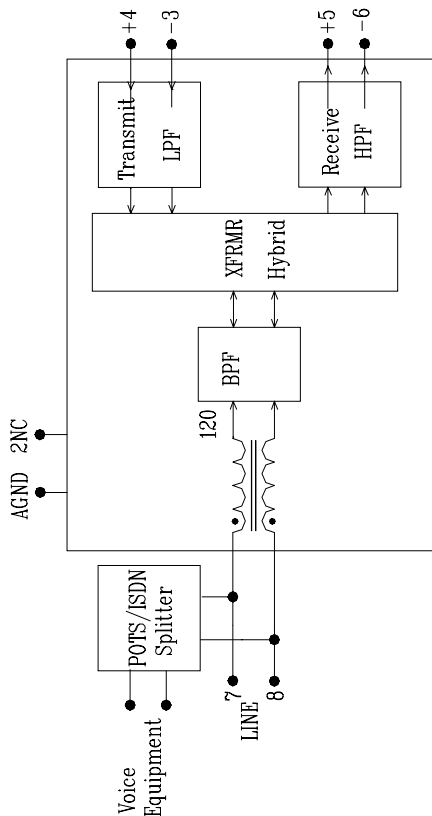

PIN	ALLOCATION
1	AGND
2	NC
3	TX-
4	TX+
5	RX+
6	RX-
7	LINE
8	LINE

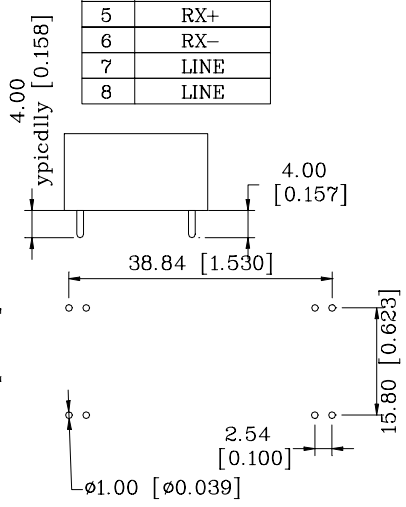

Units: mm[Inches] Tolerances: xx.x0±0.25[0.010]
 0.xx±0.05[0.002]