



P/N: HR001K DATA SHEET

Feature



- Design to meet,UL94v-0.
- Operating temperature: -10°C to +60°C.
- Storage temperature: -25°C to +75°C.

Electrical Specifications @ 25°C

Filter Type	Insertion Loss (dB Max)	OCL (uH Min) @100KHz/0.1V with 8mA DC Bias	Return Loss (dB Min)						CMR (dB Min)
			1MHz	30MHz	40MHz	50MHz	60MHz	80MHz	
100Base-Tx	-1.1	350	-18	-18	-15.5	-13.6	-12	-12	-34

Continue

Filter Type	Insertion Loss (dB Max)	Cut-Off Freq (MHz)	Return Loss (dB Min)	Attenuation (dB Min)	
				1MHz	27MHz
Band Pass Filter	-3.0	5.2-5.8	-10	-60	-50

Schematic

Mechanical

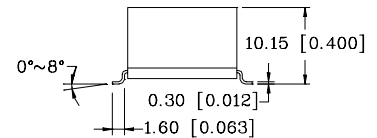
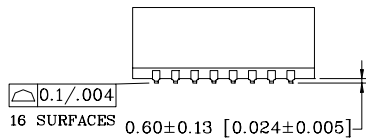
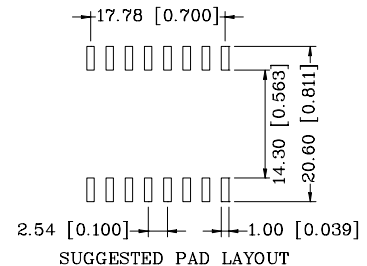
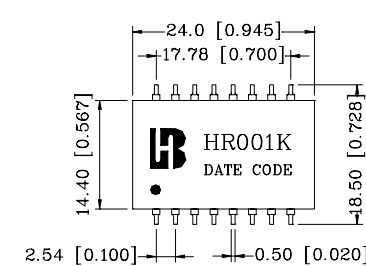
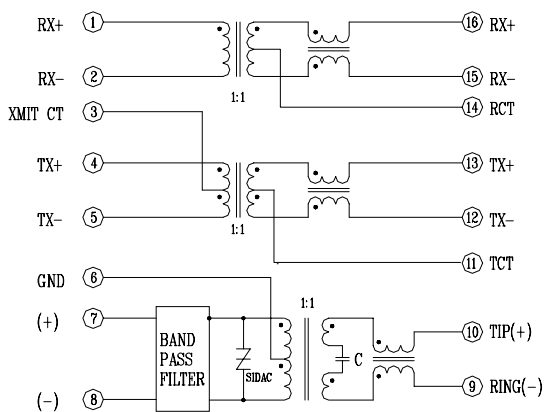

Units: mm[Inches] Tolerances: xx.x0±0.25[0.010]
0.xx±0.05[0.002]