

SINGLE RJ45 CONNECTOR MODULE WITH INTEGRATED 10 BASE-T MAGNETICS

P/N : LT1S104A

Page : 1/1

Feature



- RJ-45 connector integrated with X'FMR.
- Size same as RJ-45 connector to save PCB Board space.
- Reduce EMI radiation, improve EMI performance.
- Complies with IEEE 802.3 standards.
- Operating temperature range: 0°C to +70°C.
- Storage temperature range: -25°C to +125°C.

Electrical Specifications @ 25°C					
Part Number	Turns Ratio (±5%)		OCL (uH Min) @ 100KHz/0.2V	L.L (uH Max)	C _{w/w} (pF Max)
	TX	RX			
LT1S104A	1CT:1	1CT:1	140	0.4	12

Schematic

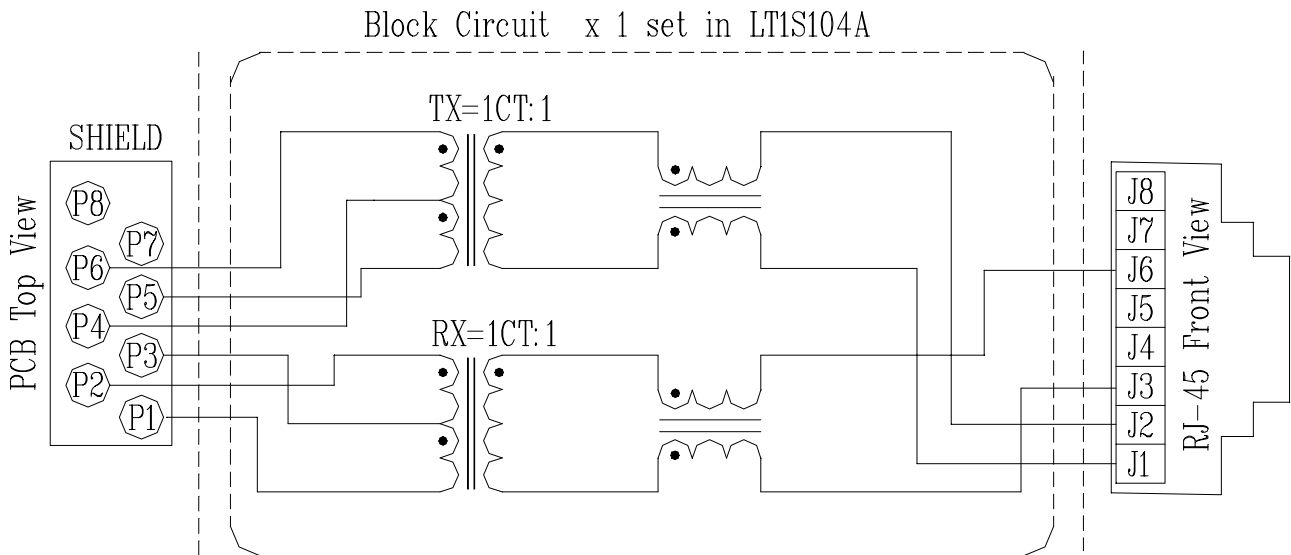

SINGLE RJ45 CONNECTOR MODULE WITH INTEGRATED 10 BASE-T MAGNETICS

P/N : LT1S104A

Mechanical

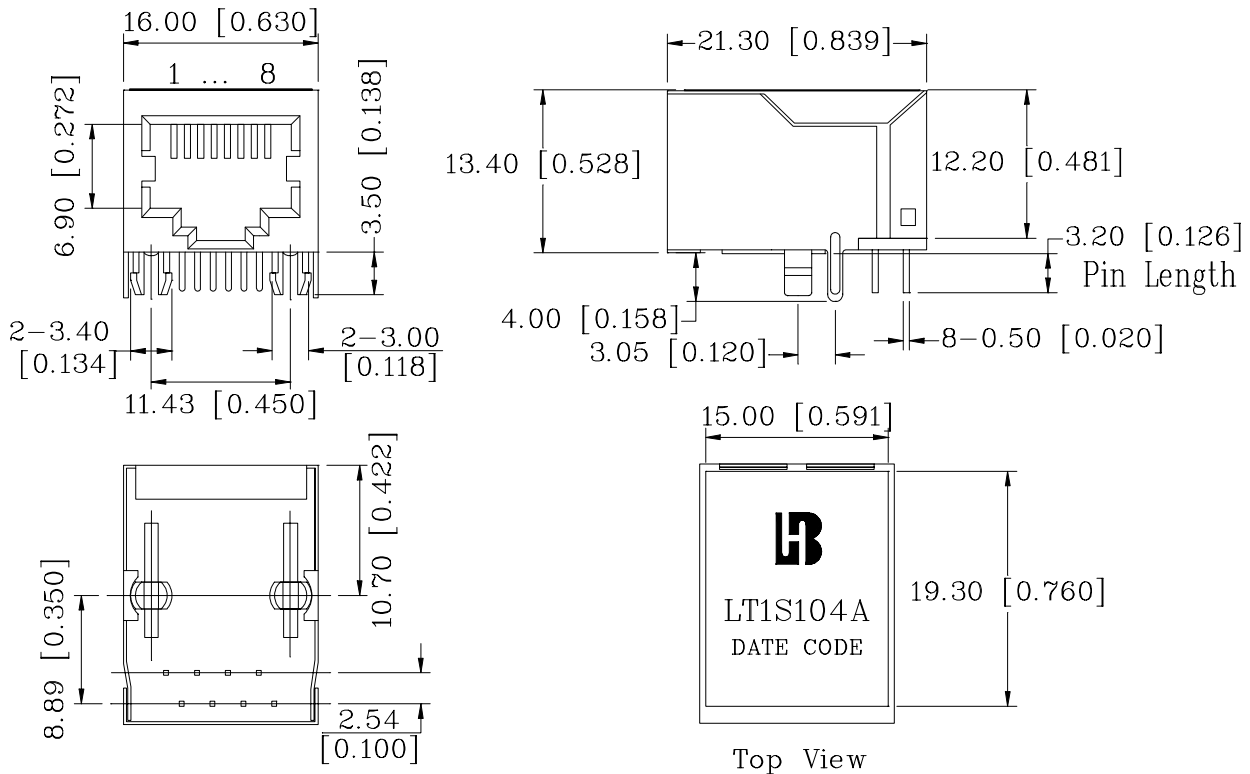

Units: mm[Inches] Tolerances: xx.x0±0.25[0.010]

0.xx±0.05[0.002]

- 1. Plastic Material : PBT 15% Glass Filled(UL 94V-0), Black Housing.
- 2. Metal Shield : Brass C2680-H, 20u Nickel Plated, t=0.25mm.
- 3. Spring Wire : 0.45mm Dia. Phosphor bronze with 6u gold plated.
- 4. Solder Pin : 0.4x0.4mm, Phosphor bronze with solder Plated.
- 5. Durability : 300 Mating cycles Min.

PCB Layout Mounting Hole(Top View)

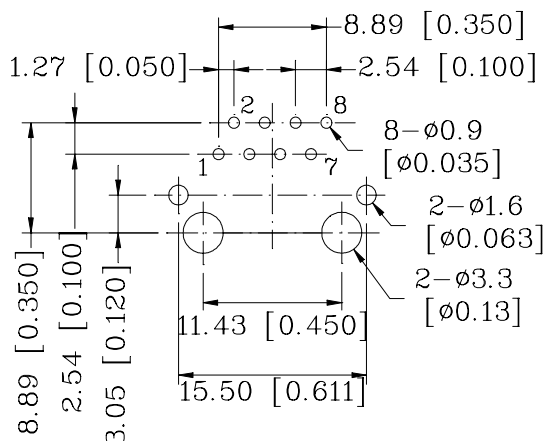

Units: mm[Inches]

Tolerances: xx.x0±0.25[0.010]

0.xx±0.05[0.002]